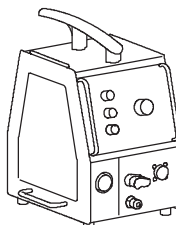
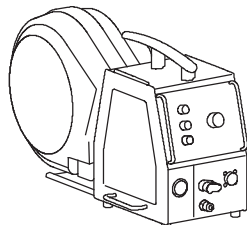
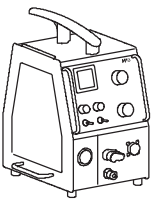
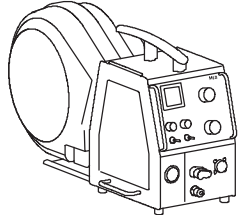

Spare parts list

Edition 140310

Valid for serial no. 238-xxx-xxxx, 410-xxx-xxxx, 440-xxx-xxxx, 502-xxx-xxxx, 620-xxx-xxxx, 917-xxx-xxxx, 236-xxx-xxxx (year 2012 week 36)

	Feeder for Marathon Pac™	Feeder with capsuled bobbin
		
	23 pole	23 pole
Product	Ordering no.	Ordering no.
Origo™ Feed 304, M12	0459 114 882	0459 116 882
Origo™ Feed 304, M12, US version	-	0459 116 482
Origo™ Feed 304, M12 with water cooling	0459 114 892	0459 116 892
Origo™ Feed 484, M12	0459 114 982	0459 116 982
Origo™ Feed 484, M122 with water cooling	0459 114 992	0459 116 992

	Feeder for Marathon Pac™	Feeder with capsuled bobbin	Feeder with capsuled bobbin
			
Product	23 pole	23 pole	19 pole
	Ordering no.	Ordering no.	Ordering no.
Origo™ Feed 304, M13	0459 114 883	0459 116 883	0459 116 863
Origo™ Feed 304, M13 with display	0459 114 884	0459 116 884	0459 116 864
Origo™ Feed 304, M13 with water cooling	0459 114 893	0459 116 893	0459 116-873
Origo™ Feed 304, M13 with water cooling and display	0459 114 894	0459 116 894	0459 116 874
Origo™ Feed 484, M13	0459 114 983	0459 116 983	0459 116 963
Origo™ Feed 484, M13 with display	0459 114 984	0459 116 984	0459 116 964
Origo™ Feed 484, M13 with water cooling	0459 114 993	0459 116 993	0459 116 973
Origo™ Feed 484, M13 with water cooling and display	0459 114 994	0459 116 994	0459 116 974

The wire feeders are renamed:

New name	Old name
Origo™ Feed 304, M12	ESABFeed 30-4, M12
Origo™ Feed 484, M12	ESABFeed 48-4, M12
Origo™ Feed 304, M13	ESABFeed 30-4, M13
Origo™ Feed 484, M13	ESABFeed 48-4, M13

Spare parts are to be ordered through the nearest ESAB agency. Kindly indicate type of unit, serial number, denominations and ordering numbers according to the spare parts list.

Maintenance and repair work should be performed by an experienced person, and electrical work only by a trained electrician. Use only recommended spare parts.

Rights reserved to alter specifications without notice.

C = component designation in the circuit diagram

Item	Qty	Ordering no.	Denomination	Notes	C
HA1	1	0459 119 001	Handle		
HA2	1	0459 069 004	Side panel		
		0459 213 001	Label for side panel		
HA3	1		Protection frame	For further information see pages 12 and 13.	
HA4	1		MMC module	Panel M12, see page 12. Panel M13, see page 13.	
HA5	1	0368 544 005	Socket	23 pole panel socket	
		0323 945 003	Sleeve	For 23 pole socket	
HA6	1	0455 516 001	Cap	23 pole	
HA7	1		Cover plug	Ø 26	
HA8			Quick connection	Male, Included in item HA17a from ser.no xxx-526-xxxx	
	1	0367 149 001	Quick connection	Male. For serial no 238-xxx-xxxx to xxx-525-xxxx	
HA9	2	0192 230 105	Cover plug		
HA11	1	0365 803 016	Quick connection	Female, Red	
HA12	1	0365 803 017	Quick connection	Female, Blue	
HA13	1	0456 496 002	Hose, blue	L=0.33, Ø 9/5mm, to be ordered per metre	
HA14	1	0456 496 001	Hose red	L=0.33, Ø 9/5mm, to be ordered per metre	
HA15			Hose clamp	Ø 11.3/10.8	
HA16	1		Water outlet with lock	For futher information see page 11.	13S1
HA17a	1	0193 054 007	Solenoid valve	From serial no. xxx-526-xxxx	13YV1
HA17b	1	0193 054 002	Solenoid valve	For serial no 238-xxx-xxxx to xxx-525-xxxx	13YV1
HA18	1	0456 496 001	Hose, red	L=0.27, Ø 9/5mm, to be ordered per metre	
HA19	1	0192 526 002	Sealing strip	L=1.34	
HA20	1	0459 148 001	Protective cover MMC panel		
HA21	1	0459 547 001	Locking device	Replacing 0367 902 001	
HA22	1	0459 069 003	Side panel		
-		0459 213 001	Label for side panel		
HA23	1	0458 777 002	Protection clamp	Handle	
HA24	1		Wire feed mechanism	Type MEL 48, Feed 484, see page 8.	
HA25	1		Wire feed mechanism	Type MEM 30, Feed 304, see page 6.	

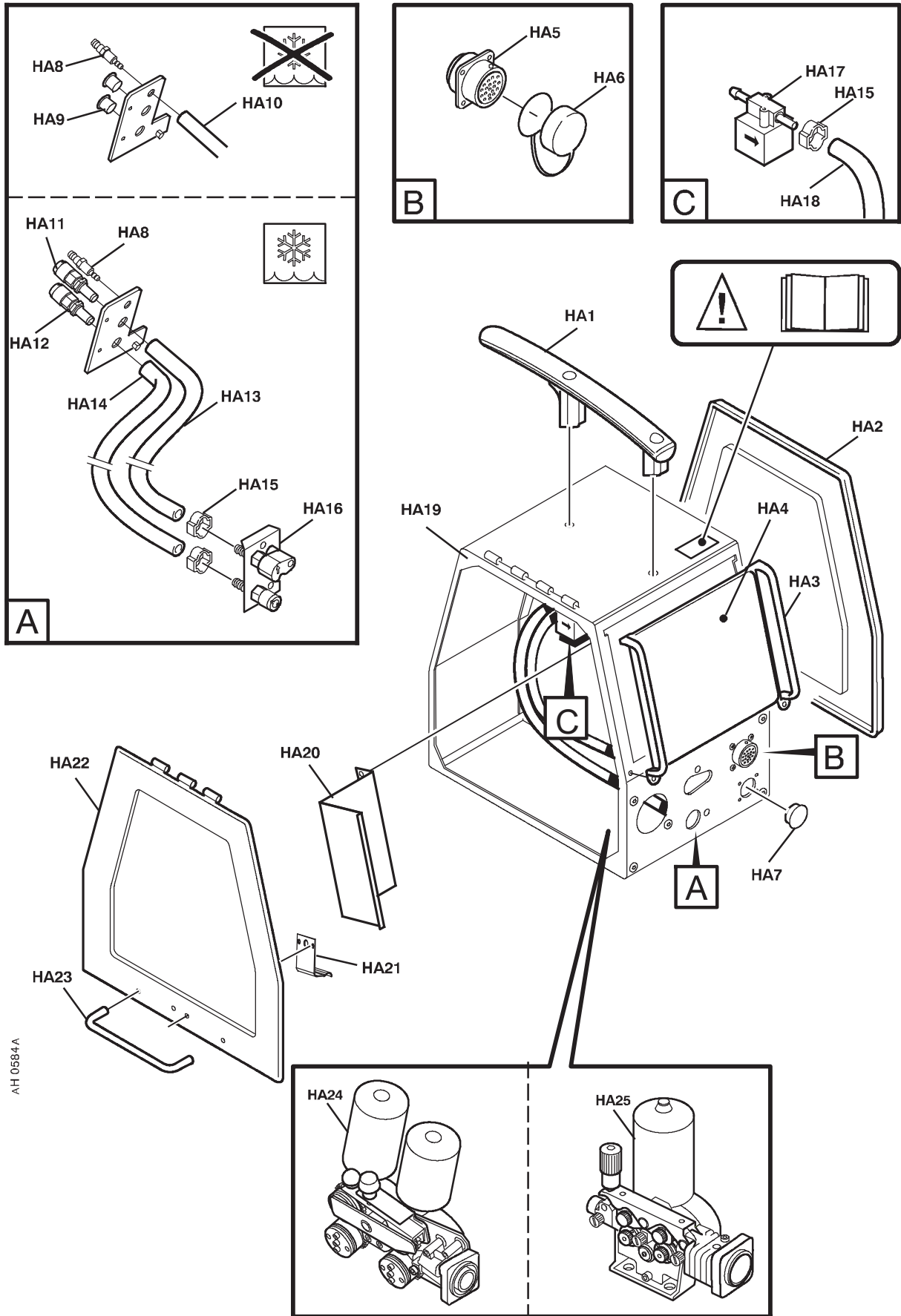

**C = component designation in the circuit diagram
(W) = wear part**

Item	Qty	Ordering no.	Denomination	Notes	C
HB1	1	0459 071 885	Cover		
HB2	1	0459 099 001	Middle plate		
HB3	1	0458 662 880	Bottom plate		
HB4	1	(W)	Inlet nozzle		
HB5	1	0458 748 001	Insulating bushing		
HB6	1	0458 748 002	Insulating washer		
HB7	1		Nut	M 10	
HB8	4	0467 695 001	Rubber foot	Ø 20/6.4x3, When ordering: 4 pieces delivered.	
HB10	1	0368 543 005	Pin socket	23 pole panel plug	13XP1
		0323 945 004	Pin	For 23 pole panel plug	
		0538 500 203	Panel plug	19 pole, pins included	
HB11	1	0459 102 001	Rear plate	For 19 pole panel plug	
		0459 102 002	Rear plate	For 23 pole panel plug	
HB12	1	0160 609 881	Welding current terminal		
HB13	1	0466 325 001	Gasket		
HB14	1		Spacer ring	Included in item HB12	
HB15	1		Washer	Included in item HB12	
HB16	1		Nut	Included in item HB12	
HB17	1	0458 678 001	Bar flexible		
HB18	1	0467 911 881	Capacitor		13C4
HB19	1		Washer	Ø 22/10.5x2	
HB20	2		Spring washer	Ø 20/10.2x1.1	
HB21	1		Screw	M10x20	
HB22	4	0194 019 005	Spacer		
HB23	1	0487 166 892	Circuit board	Feed 304 with tacho. Before ser.no. 917-xxx-xxxx	13AP1
		0487 166 893	Circuit board	Feed 484 with tacho. All serial numbers	13AP1
		0487 166 894	Circuit board	Feed 304 with encoder. From ser.no. 917-xxx-xxxx	13AP1
HB24	1	0459 108 005	Front plate water		
HB25	1	0459 108 007	Front plate air		

For wear parts see page 14.

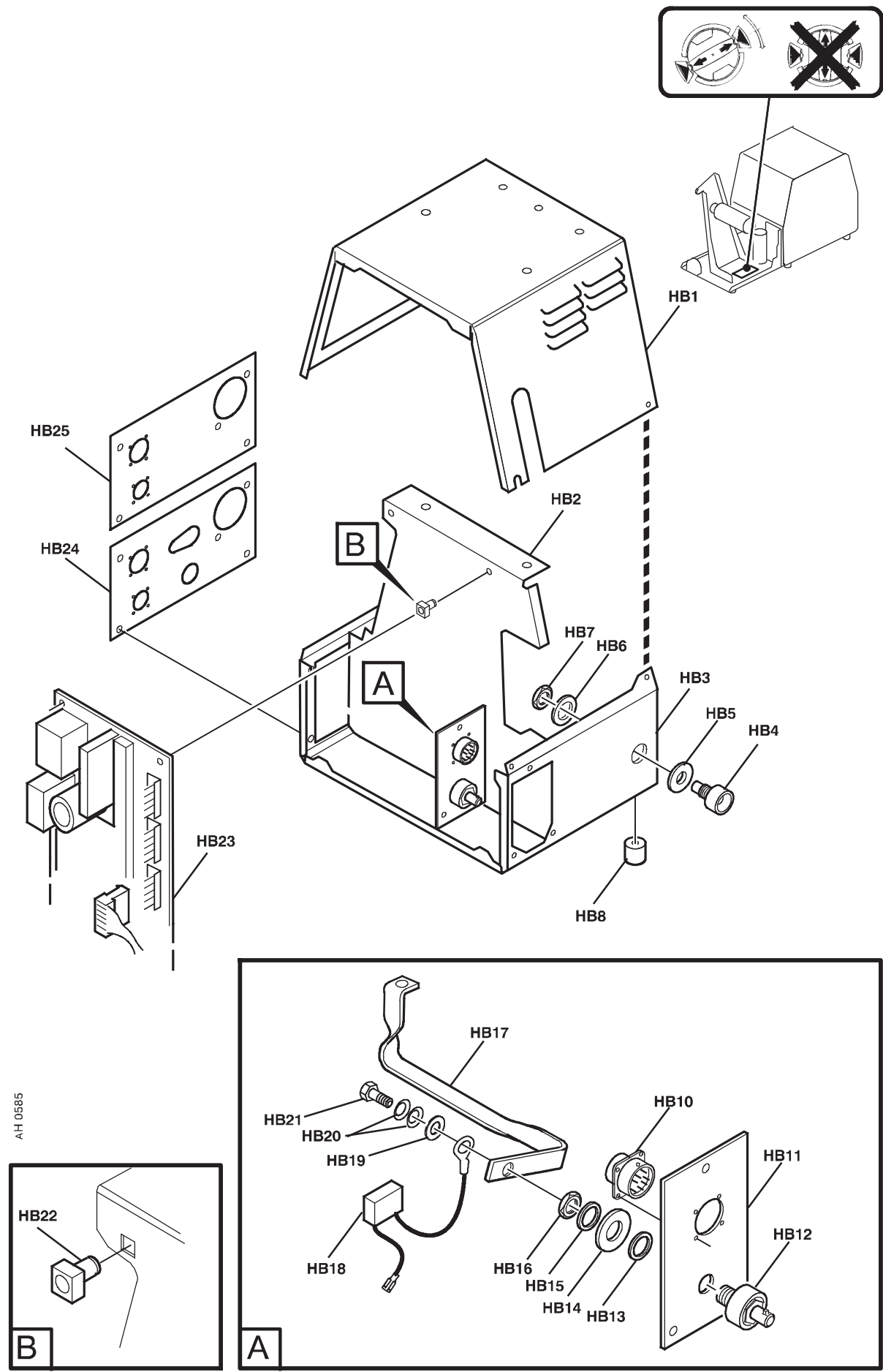

AH 0585

C = component designation in the circuit diagram

(W) = wear part

Item	Qty	Ordering no.	Denomination	Notes	C
		0459 000 882	Wire feed mechanism	Includes items HH1 - HH21 and HH23 - HH41 Type MEM 30 Before serial no. 917-xxx-xxxx	
		0459 000 896	Wire feed mechanism	Includes items HH1 - HH21 and HH23 - HH41 Type MEM 30 From serial no. 917-xxx-xxxx	
HH1	1	0455 077 001	Drive unit	With tachometer Before serial no. 917-xxx-xxxx	13M1,13G1
HH1	1	0459 808 002	Drive unit	With encoder From serial no. 917-xxx-xxxx	13M1,13G1
HH2	1	0332 351 012	Shaft (with pinion)	Included in item HH1	
HH3	1	0191 496 114	Key	Included in item HH1	
HH4	1	0215 701 007	Locking washer	Included in item HH1	
HH5	1	0455 046 003	Gear housing		
HH6	1		Screw	M6x40	
HH7	2		Washer	Ø 12/6.4x1.5	
HH8	1	0455 048 001	Insulating tube		
HH9	1		Nut	M6	
HH10	1	0467 911 880	Capacitor	0.1 µF 250V with cable lugs	13C5
HH11	1		Flat pin	6.3x0.8 M6	
HH12	4		Screw	M6x12	
HH13	1	0455 045 001	Insulating sleeve		
HH14	1	0455 044 001	Current connection		
HH15	1		Screw	M8x25	
HH16	1		Washer	Ø 16/8.4x1.5	
HH17	1		Belleville washer	Ø 16/8.2x0.9	
HH18	1		Nut	M6	
HH19	2	0368 750 001	Insulating sleeve	For cable set	
	1	0459 224 880	Cable set		
HH20	1	0458 918 880	Front flange with PC-board	Current relay	
HH21	1	(W)	Outlet nozzle		
HH22	4	0153 043 002	Insulating washer		
HH23	1	0469 838 001	Cover		
HH24	3		Screw	M6x12	
HH25	1	(W)	Drive gear		
HH26	1		Washer	Ø 16/5x1	
HH27	1		Screw	M4x12	
HH28	2		Axle feed roll	See item HH102	
HH29	4	(W)	Gear adapter		
HH30	4	(W)	Feed/pressure roller		
HH31	2		Locking nut	See item HH102	
HH32	3	0458 689 001	Screw for nozzle		
HH33	1		Pin bolt	See item HH101	
HH34	1	(W)	Inlet nozzle		
HH35	1		Pressure device	See item HH101	
HH36	1	(W)	Intermediate nozzle		
HH37	1		Pressure arm	See item HH100	
HH38	1		Locking washer	See item HH100	
HH39	1		Torsion spring	See item HH100	
HH40	1		Shaft	See item HH100	
HH41	2	0458 999 001	Shaft		

For wear parts see page 14.

SPARE PARTS SETS

Item	Ordering no.	Denomination	Notes
HH100	0459 227 880	Pressure arm set	Includes items HH37, HH38, HH39 and HH40
HH101	0459 228 880	Pressure device set	Includes items HH33, HH35 and one screw M3x12.
HH102	0458 722 880	Axle and nut	Includes items HH28 and HH31.

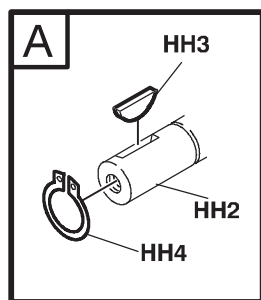
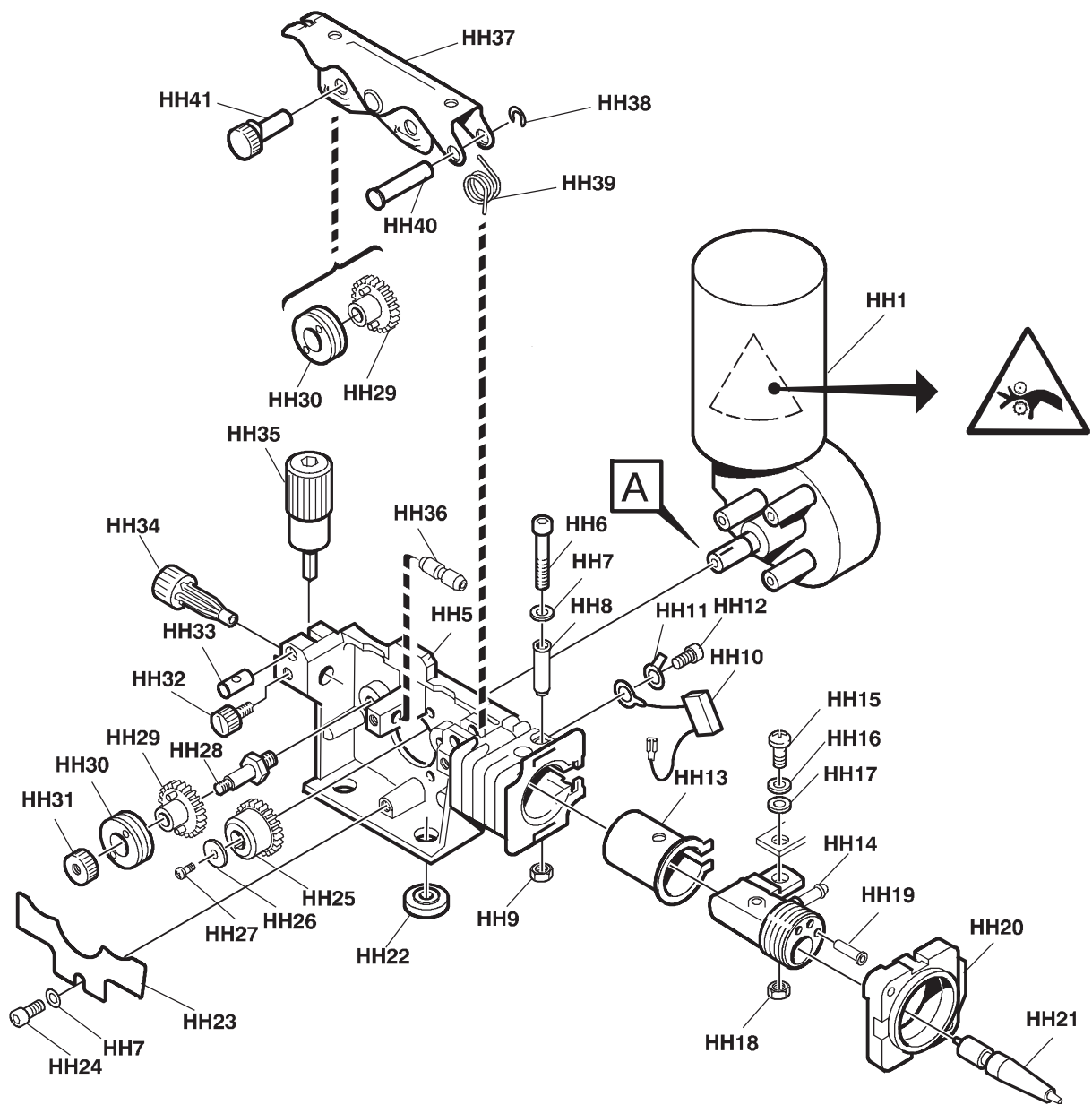

AH 0583A

C = component designation in the circuit diagram

(W) = wear part

Item	Qty	Ordering no.	Denomination	Notes	C
		0458 547 881	Wire feed mechanism	Includes items HD1 - HD27 and HD29 Type MEL 48	
HD1	1	0156 728 010	Drive unit	With tachometer	13M2
-	1	0193 260 063	Connector	4 pole	13XS4
HD2	1	0156 728 011	Drive unit		13M3
	1	0191 548 010	Flat pin	6.3x0.8 M10	
	6		Nut	M8	
HD3	1	0467 911 880	Capacitor	0.1 µF 250V with cable lugs	13C6
HD4	1		Screw	M6X40	
HD5	1		Washer	Ø 6.4/12x1.5	
HD6	1	0455 048 001	Insulating tube		
HD7	1	0458 545 001	Connection housing		
HD8	9		Screw	M5X20	
HD9	1		Screw	M6X16	
HD10	1		Nut	M6	
HD11	1	0458 918 880	Front flange with PC.board	Current relay	
HD12	1	0455 044 001	Current connection		
HD15	1	(W)	Outlet nozzle		
HD16	2	(W)	Feed roller		
HD17	4	0156 707 001	Distance washer		
HD18	2	0156 707 002	Adjustement spacer		
HD19	2	0366 944 001	Washer		
HD20	2		Screw	M5x16	
HD21	1	(W)	Bogey		
HD23	1	0366 961 001	Inter nozzle support		
HD24	2	0215 702 708	Locking washer		
HD25	1	(W)	Intermediate nozzle		
HD26	1		Wire feed plate		
HD27	1	0366 962 001	Bogey axle		
-	1		Screw	M8X30	
-	1		Washer	Ø 26/8.4X5	
HD28	4	0153 043 002	Insulating washer		
HD29	1	0368 750 001	Insulating sleeve	For cable set	
	1	0459 229 880	Cable set		

For wear parts see page 16.

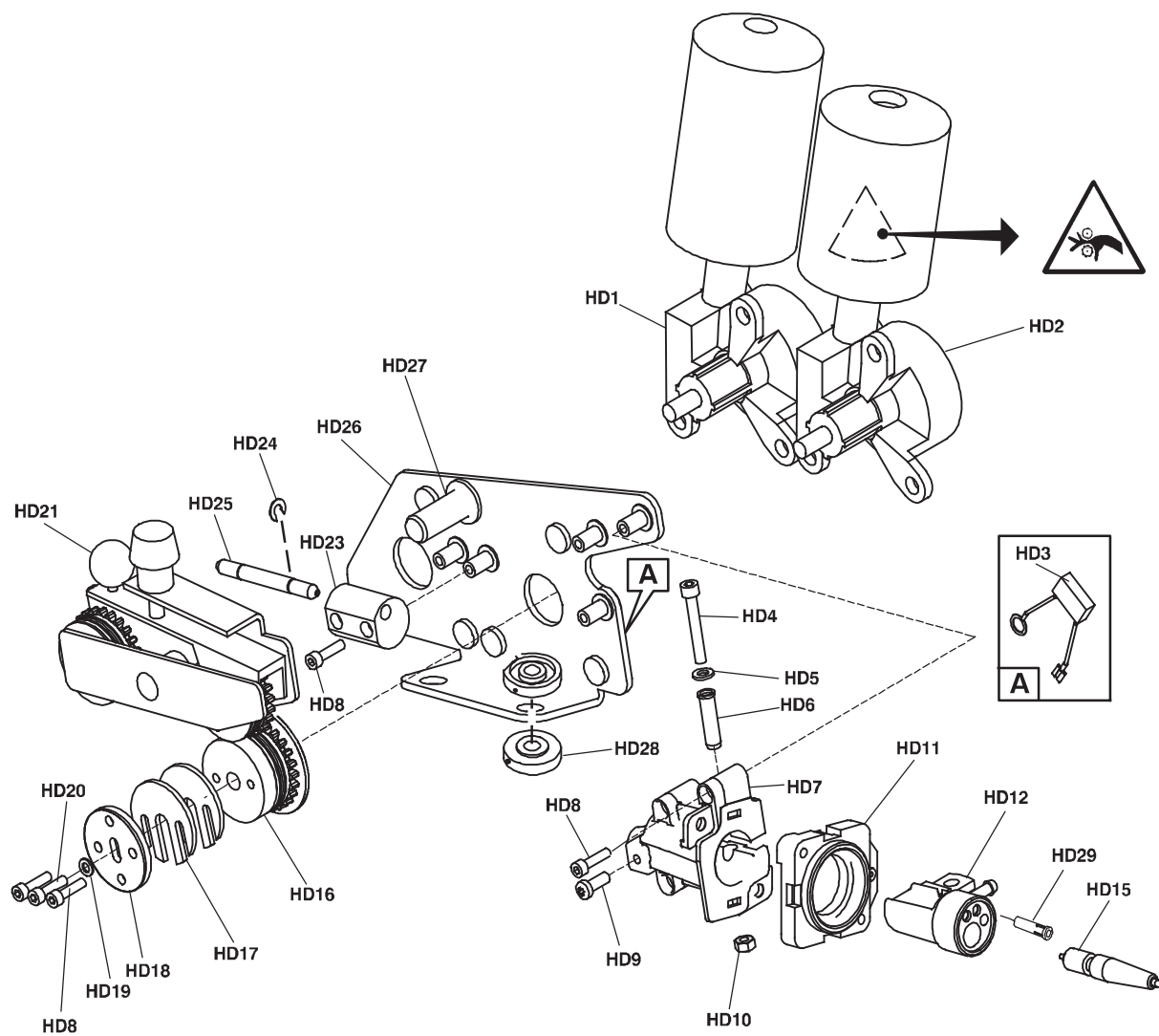

0489Q1

Item	Qty	Ordering no.	Denomination	Notes
HE3	1	0458 674 880	Bobbin cover	
HE4	1	0146 967 881	Brake hub	
HE5	1	0459 294 881	Spool attachment	
HE6	1	0156 633 003	Reel cover	

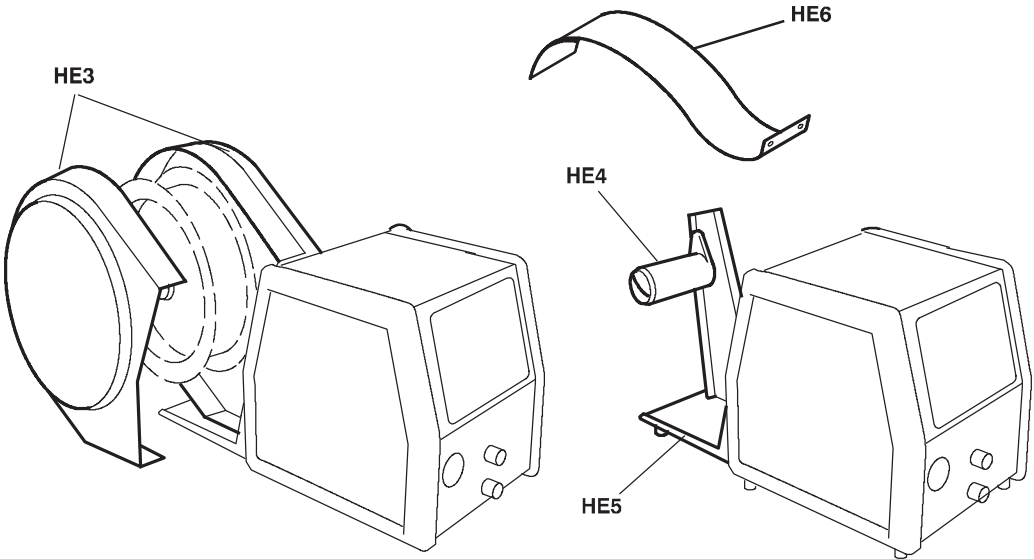

Item	Qty	Ordering no.	Denomination	Notes
HF1	1		Nut	M5
HF2	1		Washer	D16/5x1
HF3	1		Spring	
HF4	1		Water lock cam	
HF5	1	0365 803 015	Quick connector	Female, blue
HF6	1		Water lock bushing	
HF7	1		Water lock outlet	
HF8	1		Screw	M5x35
HF9	1		Nut	M3
HF10	1	0458 589 001	Insulation plate	
HF11	1	0458 364 001	Micro switch	
HF12	1	0365 803 014	Quick connector	Female, red
HF13	2		Screw	M3x20
HF14	2		Nut	M3

SPARE PARTS SET

Item	Qty	Ordering no.	Denomination	Notes
HF50	1	0458 370 900	Water connection spare kit	Contains items HF1, HF2, HF3, HF4, HF6, HF7 and HF8

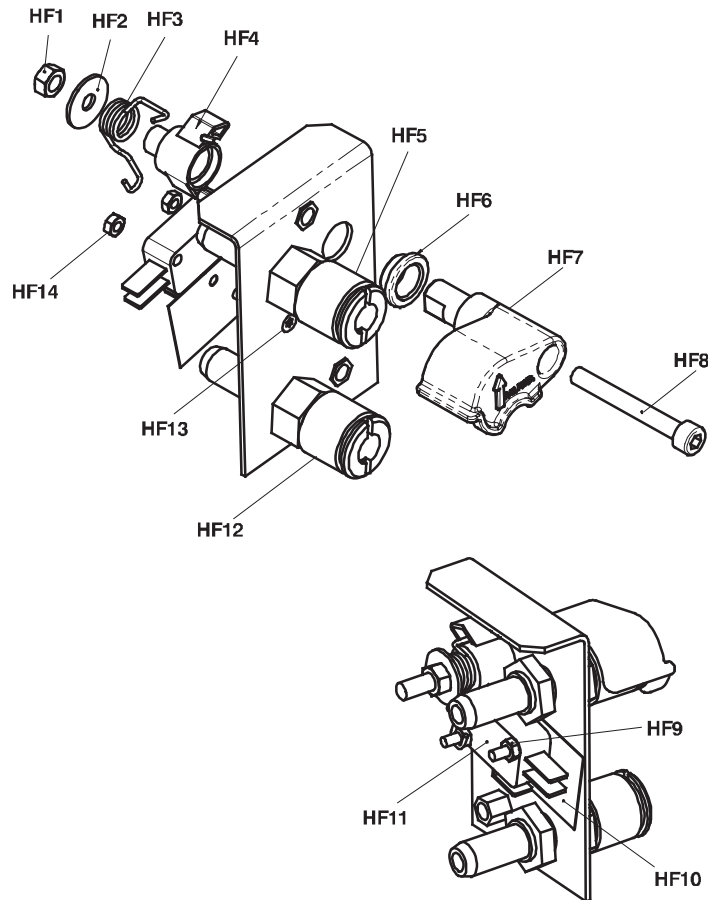

H

Control panel M12

C = component designation in the circuit diagram

Item	Qty	Ordering no.	Denomination	Notes	C
MMC module					
HJ1	1	0459 118 001	Protection frame		13RP1, 13RP3
HJ2	1	0459 131 015	Label		
HJ3	2	0191 870 616	Potentiometer		
HJ4	1	0321 475 882	Knob	Black	
HJ4	1	0460 600 836	Knob	Grey	
HJ5	3	0321 475 881	Knob	Black	
HJ5	3	0460 600 821	Knob	Grey	13SA1, 13SA2
HJ6	2	0194 055 003	Rotary switch	2 pole	

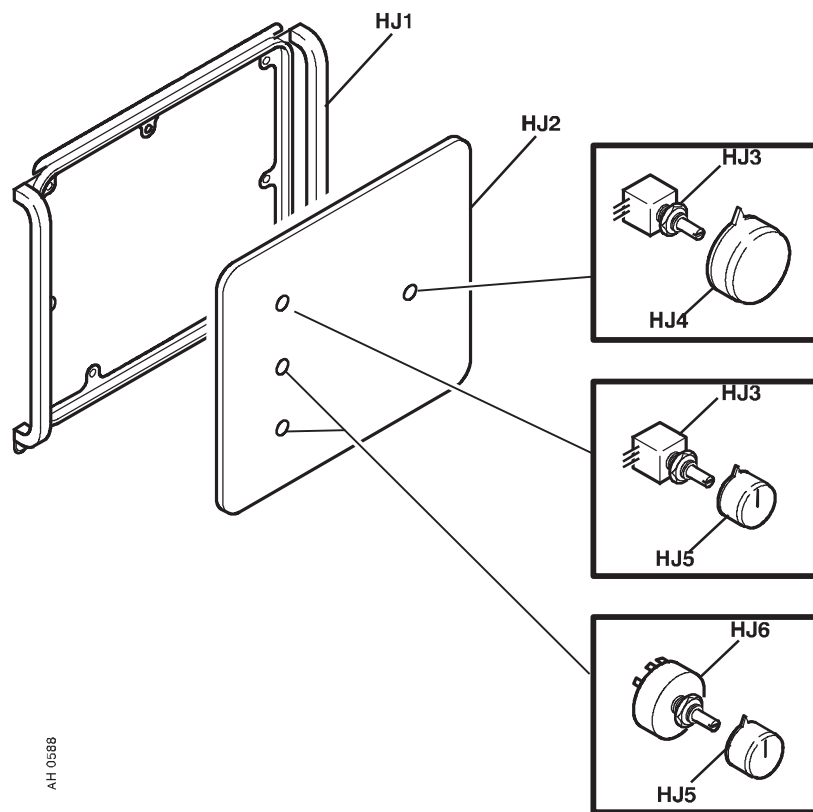

Control panel M13

C = component designation in the circuit diagram

Item	Qty	Ordering no.	Denomination	Notes	C
			MMC module	Panel M13	
HJ1	1		PC-board	See item HJ100	13AP2
HJ2	1	0459 118 001	Protection frame		
HJ3	1	0459 131 016	Label		
HJ4	2	0191 870 616	Potentiometer		13RP1, 13RP2
HJ5	1	0460 600 836	Knob		
HJ6	1	0455 172 001	Instrument glass		
HJ7	1	0455 174 001	Gasket		
HJ8	1	0193 951 001	Potentiometer	10 kohm, 1pole	13RP4
HJ9	1	0460 600 821	Knob		
HJ10	2	0147 866 008	Switch	2 pole	13SA1, 13SA2
HJ11	2	0147 866 009	Cover		
HJ12	3		Spacer screw	See item HJ100	
HJ13	1	0460 600 321	Knob		

SPARE PARTS SET

Item	Ordering no.	Denomination	Notes
HJ100	0455 173 882	Digital volt / ampere meter	Includes item HJ1 and HJ12

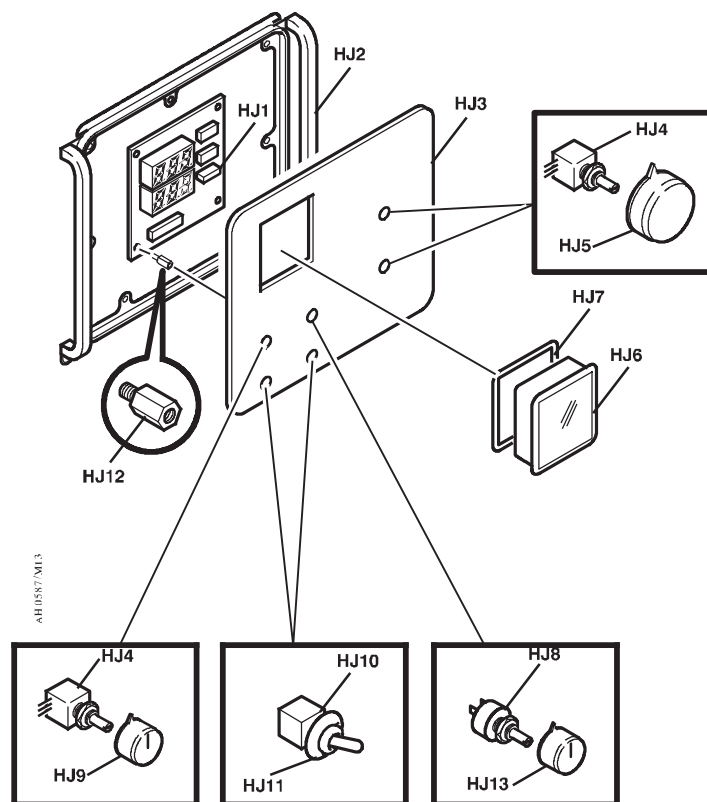

Wear parts

Item	Ordering no.	Denomination	Notes	Wire type	Wire dimensions
HI1	0455 072 002 0456 615 001	Intermediate nozzle Intermediate nozzle		Fe, Ss & cored Al	
HI2	0469 837 880 0469 837 881	Outlet nozzle Outlet nozzle		Fe, Ss & cored Al	Ø 2.0 mm steel for 0.6-1.6 mm Ø 2.0 mm plastic for 0.8-1.6 mm
HI3	0191 496 114	Key			
HI4	0215 701 007	Locking washer			
HI5a	0459 440 001	Motor gear euro	Drive gear		

Item	Ordering no.	Denomination	Wire type	Wire dimensions	Groove typ	Roller markings
HI5b	0459 052 001	Feed/pressure rollers	Fe, Ss & cored	Ø 0.6 & 0.8 mm	V	0.6 S2 & 0.8 S2
	0459 052 002	Feed/pressure rollers	Fe, Ss & cored	Ø 0.8 & 1,0 mm	V	0.8 S2 & 1.2 S2
	0459 052 003	Feed/pressure rollers	Fe, Ss & cored	Ø 0.9/1.0 & 1.2 mm	V	1.0 S2 & 1.2 S2
	0459 052 013	Feed/pressure rollers	Fe, Ss & cored	Ø 1.4 & 1.6 mm	V	1.4 S2 & 1.6 S2
	0458 825 001	Feed/pressure rollers	Cored	Ø 0.9/1.0 & 1.2 mm	V-Knurled	1.0 R2 & 1.2 R2
	0458 825 010	Feed/pressure rollers	Cored	Ø 1.2 & 1.2 mm	V-Knurled	1.2 R2 & 1.2 R2
	0458 825 002	Feed/pressure rollers	Cored	Ø 1.2 & 1.4 mm	V-Knurled	1.2 R2 & 1.4 R2
	0458 825 003	Feed/pressure rollers	Cored	Ø 1.6 & 2.0 mm	V-Knurled	1.6 R2 & 2.0 R2
	0458 824 001	Feed/pressure rollers	Al	Ø 0.8 & 0.9/1.0 mm	U	0.8 A2 & 1.0 A2
	0458 824 002	Feed/pressure rollers	Al	Ø 1.0 & 1.2 mm	U	1.0 A2 & 1.2 A2
	0458 824 003	Feed/pressure rollers	Al	Ø 1.2 & 1.6 mm	U	1.2 A2 & 1.6 A2

Use only pressure and feed rollers marked **A2**, **R2** or **S2**.
The rollers are marked with wire dimension in mm, some are also marked with inch.

Item	Ordering no.	Denomination	Notes
HI6		Washer	Ø 16/5x1
HI7		Screw	M4x12
HI8		Screw	M6x12
HI9		Washer	Ø 16/8.4x1.5
HI10	0469 838 001	Cover	
HI11	0458 722 880	Axle and Nut	
HI12	0459 441 880	Gear adapter	
HI13	0455 049 001	Inlet nozzle	Ø 3mm for 0.6-1.6mm Fe, Ss, Al and cored wire
HI14	0458 999 001	Shaft	
HI15		Nut	M10
HI16	0458 748 002	Insulating washer	
HI17	0458 748 001	Insulating bushing	

Item	Ordering no.	Denomination	Wire type	Wire dimensions
HI18	0156 602 001	Inlet nozzle	Fe, Ss, Al & Cored	Ø 2 mm plastic for 0.6-1.6 mm

Welding with aluminium wire

In order to weld with aluminium wire, proper rollers, nozzles and liners for aluminium wire **MUST** be used, It is recommended to use 3 m long welding gun for aluminium wire, equipped with appropriate wear parts.

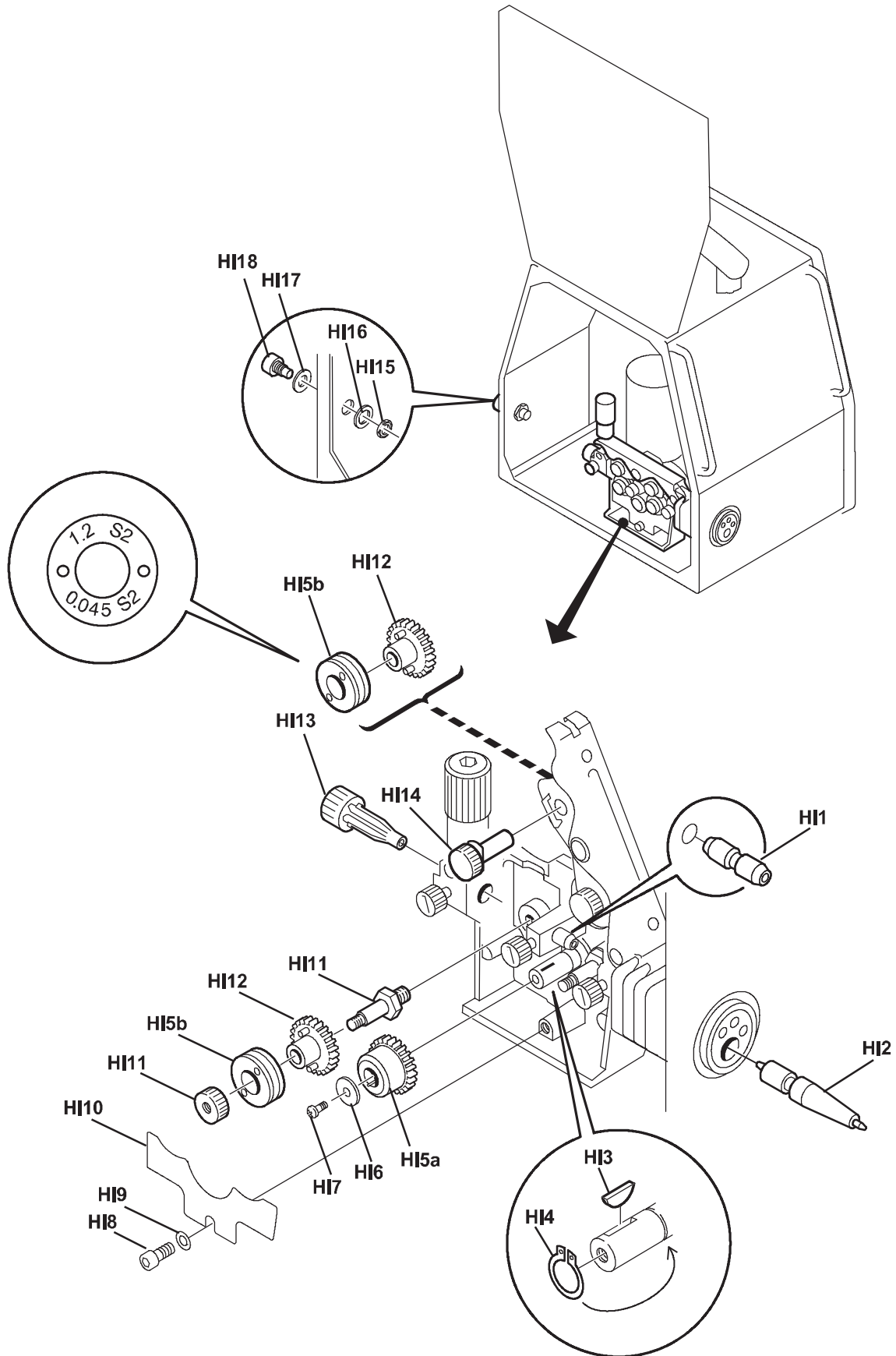

AH 0633 A

Feed 484 M12 / M13, ESABFeed 48-4 M12 / M13

Item	Ordering no.	Denomination	Wire type	Wire dimensions
HK1	0469 837 880 0469 837 881 0469 837 882	Outlet nozzle Outlet nozzle Outlet nozzle	Fe, Ss & cored Al Fe, Ss & cored	Ø 2.0 mm steel for 0.6-1.6 mm Ø 2.0 mm plastic for 1.0-1.6 mm Ø 3.4 mm steel for 2.0-2.4 mm

Item	Ordering no.	Denomination	Wire type	Wire Ø mm	Groove 1	Groove 2	Groove 3	Groove typ	Roller / Bogey markings
HK2	0366 966 880	Feed Roller	Fe, Ss & cored	0.6-1.2	0.6-0.8	0.9-1.0	1.2	V	1
	0366 966 881	Feed Roller	Fe, Ss & cored	1.4-1.6	1.4-1.6	2.0	2.4	V	2
	0366 966 888	Feed Roller	Fe, Ss & cored	0.9	0.9	0.9	0.9	V	.035
	0366 966 889	Feed Roller	Fe, Ss & cored	1.2	.045" / 1.2	.045" / 1.2	.045" / 1.2	V	.045 / 7
	0366 966 890	Feed Roller	Fe, Ss & cored	1.6	1.6	1.6	1.6	V	1/16
	0366 966 900	Feed Roller	Fe, Ss & cored	0.9-1.6	0.9-1.0	1.2	1.4-1.6	V	6
	0366 966 882	Feed Roller	Cored	1.2-2.0	1.2	1.4-1.6	2.0	V-Knurled	3
	0366 966 883	Feed Roller	Cored	2.4	2.4	not used	not used	V-Knurled	4
	0366 966 893	Feed Roller	Cored	1.2	1.2	1.2	1.2	V-Knurled	.045
	0366 966 894	Feed Roller	Cored	1.6	1.6	1.6	1.6	V-Knurled	1/16
	0366 966 885	Feed Roller	Al	1.2	1.2	1.2	1.2	U	U2
	0366 966 899	Feed Roller	Al	1.0-1.6	1.0	1.2	1.6	U	U4

Item	Ordering no.	Denomination	Notes
HK3	0156 707 001	Distance washer	
HK4	0156 707 002	Adjustment spacer	
HK5		Screw	M5x20
HK6		Screw	M5x16

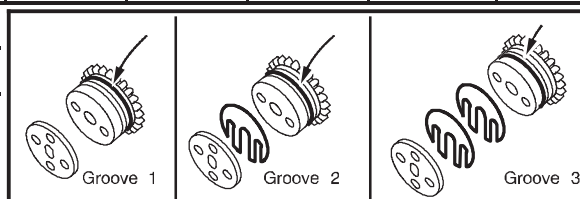

HD = Heavy Duty

Item	Ordering no.	Denomination	Wire type	Wire dimensions	Groove typ	Roller / Bogey markings
HK7	0366 902 880	Bogey (HD)	Fe, Ss & cored	Ø 0.6 - 1.2 mm	V	1
	0366 902 900	Bogey (HD)	Fe, Ss & cored	Ø 0.9 - 1.6 mm	V	6
	0366 902 881	Bogey (HD)	Fe, Ss & cored	Ø 1.4 - 2.4 mm	V	3
	0366 902 894	Bogey (HD)	Fe, Ss & cored	Ø 1.2 mm	V	.045 / 7
	0366 902 902	Bogey (HD)	Fe, Ss & cored	Ø 0.9 mm	V	.035
	0366 902 901	Bogey (HD)	Fe, Ss & cored	Ø 1.6 mm	V	1/16
	0366 902 882	Bogey (HD)	Cored	Ø 1.2 - 2.0 mm	V-Knurled	3
	0366 902 883	Bogey (HD)	Cored	Ø 2.4 mm	V-Knurled	4
	0366 902 903	Bogey (HD)	Cored	Ø 1.2 mm	V-Knurled	.045
	0366 902 904	Bogey (HD)	Cored	Ø 1.6 mm	V-Knurled	1/16
	0366 902 899	Bogey (HD)	Al	Ø 1.0 - 1.6 mm	U	U4
	0366 902 886	Bogey (HD)	Al	Ø 1.2 mm x 3	U	-

Item	Ordering no.	Denomination	Wire type	Wire dimensions
HK8	0366 944 001	Washer		
HK9	0156 603 001	Intermediate nozzle	Fe, Ss & Al	Ø 2 mm plastic for 0.6-1.6 mm
	0156 603 002	Intermediate nozzle	Fe, Ss & Al	Ø 4 mm plastic for 2.0-2.4 mm
	0332 322 001	Intermediate nozzle	Cored	Ø 2.4 mm copper for 1.2-2.0 mm
	0332 322 002	Intermediate nozzle	Cored	Ø 4 mm copper for 2.4 mm

Feed 484 M12 / M13, ESABFeed 48-4 M12 / M13

Item	Ordering no.	Denomination	Note
HK10	0215 702 708	Locking washer	M10
HK11		Nut	
HK12	0458 748 002	Insulating washer	
HK13	0458 748 001	Insulating bushing	

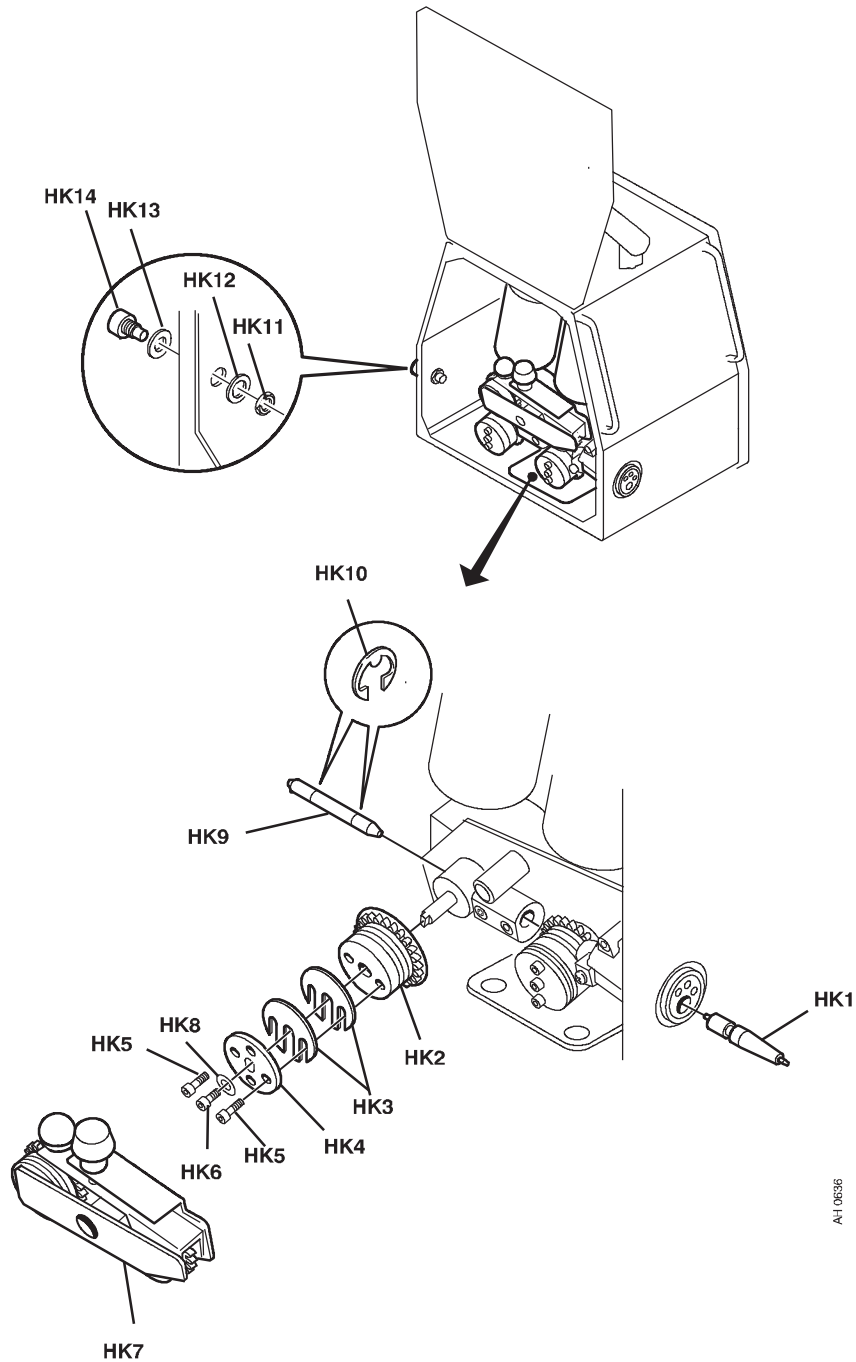

Item	Ordering no.	Denomination	Wire type	Wire dimensions
HK14	0156 602 001	Inlet nozzle	Fe, Ss, Al & Cored	Ø 2 mm plastic for 0.6-1.6 mm
	0156 602 002	Inlet nozzle	Fe, Ss, Al & Cored	Ø 4 mm plastic for 2.0-2.4 mm
	0332 318 001	Inlet nozzle (HD)	Fe, Ss & Cored	Ø 2.4 mm steel for 1.2-2.0 mm
	0332 318 002	Inlet nozzle (HD)	Fe, Ss & Cored	Ø 4 mm steel for 2.4 mm

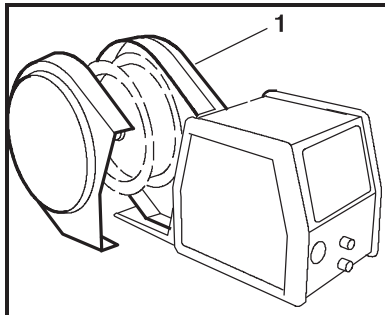
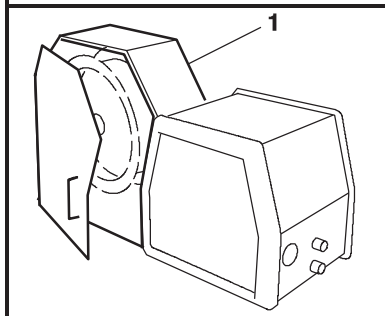
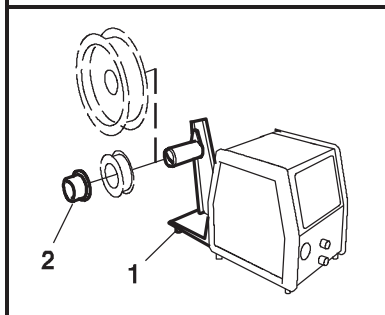
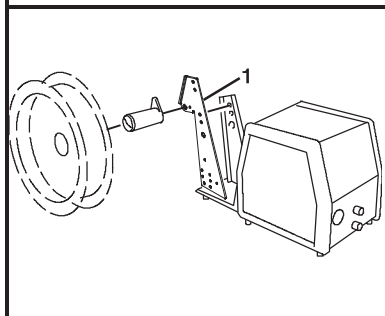
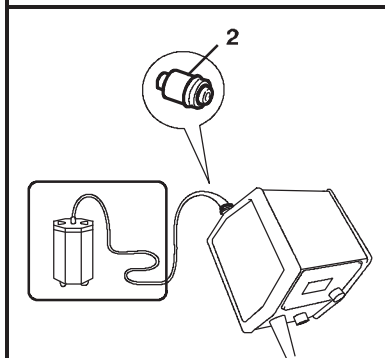

A-1 00536

Accessories

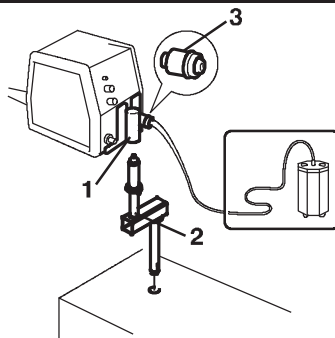
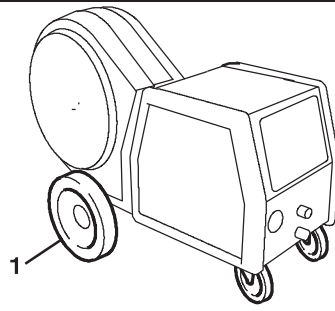
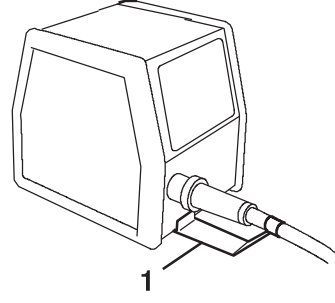
	<p>1 Bobbin cover, plastic Ø 300mm 0458 674 880</p>
	<p>1 Bobbin cover, metal Ø 300mm 0459 431 880</p>
	<p>1 Bobbin holder 0458 704 880 2 Adapter for 5 kg bobbin 0455 410 001</p>
	<p>1 Adapter for 440 mm bobbin 0459 233 880</p>
	<p>1 Lifting eye 0458 706 880 2 Quick connector MarathonPac™ F102 440 880</p>

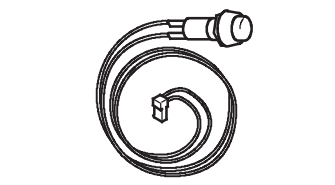
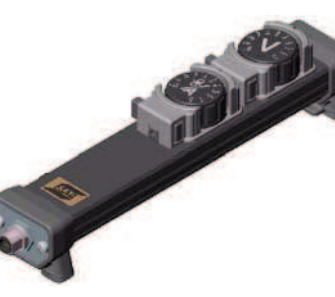
	<p>1 Turning piece 0458 703 880 2 Guide pin 0349 302 303 3 Quick connector MarathonPac™ F102 440 880</p>
	<p>1 Wheel kit 0458 707 880</p>
	<p>1 Strain relief for welding gun 0457 341 881</p>
	<p>Strain relief bracket for connection set 0459 234 880</p>
	<p>Push button for cold wire feed or gas purging 0459 465 880</p>
	<p>Remote control unit M1 0459 491 895 MIG/MAG:wire feed speed and voltage</p>

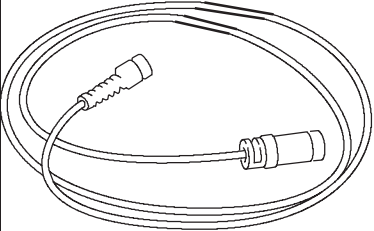
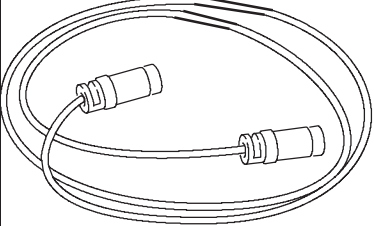
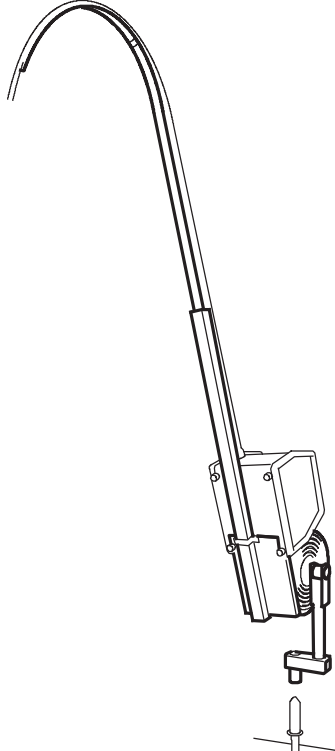
	<p>Remote cable 23 pole - 8 pole 5 m 0459 553 880</p>
	<p>Extension cable for remote control 23 pole 8 m 0467 197 880 16 m 0467 197 881</p>
	<p>Counter balance device 0458 705 880 (includes mast and counter balance)</p>

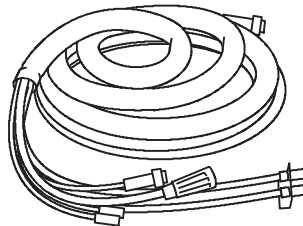
	Connection set for 400 A power sources		
		23 poles	19 poles
	1.7 m	0469 836 880	0459 836 880
	5 m	0469 836 981	0459 836 881
	10 m	0469 836 881	0459 836 882
	15 m	0469 836 882	0459 836 883
	25 m	0469 836 883	0459 836 884
	35 m	0469 836 884	0459 836 885
	1.7 m, water	0469 836 885	0459 836 890
	5 m, water	0469 836 983	0459 836 891
	10 m, water	0469 836 886	0459 836 892
	15 m, water	0469 836 887	0459 836 893
	25 m, water	0469 836 888	0459 836 894
	35 m, water	0469 836 889	0459 836 895
	Connection set for 500 A power sources		
	1.7 m	0469 836 890	0459 836 980
	5 m	-	0459 836 981
	10 m	0469 836 891	0459 836 982
	15 m	0469 836 892	0459 836 983
	25 m	0469 836 893	0459 836 984
35 m	0469 836 894	0459 836 985	
1.7 m, water	0469 836 895	0459 836 990	
5 m	-	0459 836 991	
10 m, water	0469 836 896	0459 836 992	
15 m, water	0469 836 897	0459 836 993	
25 m, water	0469 836 898	0459 836 894	
35 m, water	0469 836 899	0459 836 995	

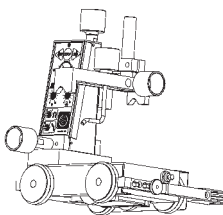
	Miggytrac 1001, Miggytrac 2000	
	Equipment for mechanized welding	More information at the nearest ESAB agency
	Control cable	
5.0 m, 23 poles	0457 360 880	

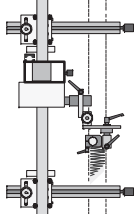
	Railtrac	
	Equipment for mechanized welding	More information at the nearest ESAB agency

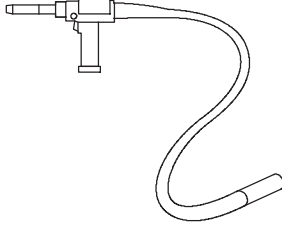
	N.B.: MXH PP only recommended for Feed 304/3004/L3004	
	Welding gun MXH 400w PP	
	6.0 m	0700 200 015
	10.0 m	0700 200 016
	10.0 m, 45°	0700 200 019
	Welding gun MXH 300w PP	
	6.0 m	0700 200 017
	10.0 m	0700 200 018
	10.0 m, 45°	0700 200 020

Information on PSF welding guns can be found in separate brochures.

„SPAW – SERWIS”

& **ECM Electronic**



**AUTORYZOWANY SERWIS SPAWAREK ORAZ ZGRZEWAREK
KRAJOWYCH I ZAGRANICZNYCH. AUTOMATYKA PRZEMYSŁOWA**

„SPAW - SERWIS” 42-200 Częstochowa, ul. Wały Dwernickiego 121
ECM Electronic 42-200 Częstochowa, ul. Tartakowa 8
www.spaw-serwisch.pl ; tel/fax. (34) 368-15-78; tel. kom. 501-283-621; spawserwisch@gmail.com

SERWIS GWARANCYJNY I POGWARANCYJNY: 42-200 CZĘSTOCHOWA ul. Tartakowa 8

Tel./fax: (34) 3 681-578; tel. kom: 501-283-621.

Adres korespondencyjny: „SPAW – SERWIS” 42-200 Częstochowa ul. Tartakowa 8, (Serwis Spawarek)

Tel./fax: (34) 3 681-578; tel. kom: 501-283-621; spawserwisch@gmail.com

OFERTA

SERWIS W ZAKRESIE URZĄDZEŃ SPAWALNICZYCH OBEJMUJE:

- PROSTOWNIKI SPAWALNICZE KLASYCZNE MMA, TIG (AC/DC i DC)
- PROSTOWNIKI SPAWALNICZE INWERTEROWE TIG, MMA (AC/DC i DC)
- PÓLAUTOMATY SPAWALNICZE MIG/MAG
- SPAWARKI Z PRZEKSZTAŁNIKAMI TYRYSTOROWYMI
- URZĄDZENIA DO CIĘCIA I SPAJANIA PLAZMOWEGO
- AGREGATY I ZESTAWY SPAWALNICZE GENERATOROWE
- PROSTOWNIKI I PRZEKSZTAŁNIKI DO ŁADOWANIA AKUMULATORÓW
KWASOWYCH I ZASADOWYCH
- URZĄDZENIA ROZRUCHOWE POJAZDÓW I ZASILACZE AKP
- ZGRZEWARKI W CZ , OPOROWE I INWERTEROWE
- ZGRZEWARKI DO ELEKTROZŁĄCZEK I DOCZOŁOWE DO INSTALACJI Z PE
- CHŁODNICE PŁYNU DO URZĄDZEŃ SPAWALNICZYCH ORAZ PRZEMYSŁOWE
- PROSTOWNIKI I PRZEKSZTAŁNIKI GALWANIZERSKIE, TECHNOLOGICZNE
- MANIPULATORY, PODAJNIKI, PRZYSTAWKI, KOMPRESORY I SPRĘŻARKI
- ROBOTY I AUTOMATYCZNE LINIE DO CIĘCIA I SPAWANIA
- PIECE HARTOWNICZE INDUKCYJNE, OPOROWE, SYLITOWE
- PIECE DO OBRÓBKI CIEPLNEJ I TOPIENIA METALI KLASYCZNE, W CZ ORAZ
INWERTEROWE
- CIĄGI I URZĄDZENIA ODPYLAJĄCE ORAZ PRZEWIETRZAJĄCE
- GENERATORY, PRĄDNICE I URZĄDZENIA PRĄDOTWÓRCZE
- FAŁOWNIKI, NAPĘDY, ZASILACZE I REGULATORY AC, DC
- UPS I URZĄDZENIA ZASILANIA AWARYJNEGO
- MIERNIKI I URZĄDZENIA POMIAROWE MEDIÓW I PARAMETRÓW
- URZĄDZENIA HYDRAULIKI I PNEUMATYKI PRZEMYSŁOWEJ
- POMPY, NARZĘDZIA I URZĄDZENIA MECHANICZNE I BUDOWLANE
- ELEKTRONARZĘDZIA, NARZĘDZIA, PRZYRZĄDY SPALINOWE I ELEKTRYCZNE
- KLIMATYZATORY MIEJSCOWE I CENTRALNE CIĄGÓW TECHNOLOGICZNYCH
- SPALINOWE SPAWARKI, ELEKTROWNIE, ZESTAWY I AGREGATY PRĄDOTWÓRCZE
NA PODWOZIACH KOŁOWYCH CIĄGNIONYCH I STACJONARNE
- SPRĘŻARKI I KOMPRESORY, POMPY I AGREGATY PRÓŻNIOWE
- SPRĘŻARKI ŚRUBOWE I URZĄDZENIA SPRĘŻANIA MEDIÓW GAZOWYCH

SERWIS W ZAKRESIE KONSTRUKCJI STAŁOWYCH I INNYCH OBEJMUJE:

- KONSTRUKCJE STAŁOWE, STOJAKI TRANSPORTOWE, KONSTR. TECHNOLOGICZNE,
PODWOZIA DROGOWE I TRANSPORTOWE URZĄDZEŃ (WYKONAWSTWO I REMONTY)

PROWADZIMY SERWIS, KOMIS I SPRZEDAŻ URZĄDZEŃ PRODUCENTÓW KRAJOWYCH:

„ASPA”; „BESTER”; „OZAS”; „FIGEL”; „ENEL”; „KamiTech”; „KARELMA”.

ORAZ PRODUCENTÓW ZAGRANICZNYCH: „ESAB”; „KEMPPPI”; „GenSet”; „KEMPER”; JLT;

„ELEKTRA BECKUM”; „Einhell”; „MOSA”; „LINCOLN ELECTRIC”; SELCO; i innych firm.

SERWISOWANE URZĄDZENIA OBJĘTE SĄ PEŁNĄ GWARANCJĄ, WYSTAWIAMY RÓWNIEŻ ŚWIADECTWA ZGODNOŚCI Z NORMAMI I CERTYFIKATMI, WYKONUJEMY PRZEGLĄDY OKRESOWE URZĄDZEŃ I WYSTAWIAMY ŚWIADECTWA. USŁUGA WYKONYWANA JEST ZGODNIE Z NORMAMI KRAJOWYMI ORAZ ISO

Autoryzacja „LINCOLN ELEKTRIC BESTER” S.A. Certyfikat Nr. 15/2005, 3/2010, 12/2012

Autoryzacja PAS „ASPA” S.A. , „OZAS” , „ESAB”, „KamiTech”